



- 20 X 4 back lit LCD
- Numeric keys for easy data entry
- 16 function keys with macro functions and LEDs
- Serial port for printing Screens, Alarms. Floating point
- Optional RTC

The Prizm80 is a member of the Keypad based Operator Interface family from Renu Electronics. It uses a 20 X 4 back lit LCD display and has numeric keypad. It is designed for applications where frequent data entry into PLC registers is needed.

Function Keys

The Prizm80 has 16 powerful user definable function keys. The user can define actions for 3 events: when the key is pressed, while the key is pressed and when the key is released.

Multiple tasks can be assigned to a single keystroke making it a powerful tool in the machine control environment. It is also possible to assign actions for a combination of two keys pressed simultaneously.

The possible tasks include coil operations (such as coil on, off, toggle, hold on or hold off), register operations (such as write constant to registers, copy tags etc.), screen operations (such as go to a specific screen, go to the next defined screen, go to previous screen etc.), alarm operations (acknowledge alarm, print alarm, select next/previous alarm etc.) and so on.

Each key can have different functions depending on the active screen. This can be used effectively to navigate easily through the application. Access to function keys can be protected using a password.

Each function key has an LED associated with it. The LED's are mapped to a user definable register in the PLC.

Changing Data

Data entry objects can be defined in the Prizm where data is to be changed. Since every user wants different ways to edit the data, the unit provides full flexibility in cursor control and key operations during data entry. The default assignments as shown on the keypad can also be used for data entry.

A bit / coil status can also be edited in an interactive manner. The key toggles the bit status and ENT key accepts the selection. Text for the object (for example, RUN when bit is ON and STOP when bit is off) changes on the display to indicate the selected bit status making it very user friendly.

Screens

The user can define as many screens as allowed by the unit memory. A list of tasks can be defined before showing a screen, while showing a screen as well as after hiding the screen. This allows proper initialization of parameters, if needed.

Various types of objects can be placed on the screen. They include simple text objects, data display (bit type text, register data show, messages objects based on a value in the register), alarm object, error object, data entry object (bit type and register type) etc..

Data display and data entry objects support various different data formats such as integer, unsigned integer, long integer, float etc. which makes it easy to use in almost any application. Data can also be displayed in a bar graph format.

Alarms

The user can define up to 16 alarms. For faster communication with the PLC, it is possible to define all the 16 alarms as consecutive bits (1 word) in the PLC. It is possible to log alarms (optional) along with the on/off times and retrieve them later. The alarm object is used to view the alarms with many flexible view options. Keys can be assigned to acknowledge alarms, print or view next / previous alarms etc.

Setup

The Prizm80 is setup on an IBM PC using the Prizm software which is provided free of cost.

Specifications :

Power	: + 24V DC \pm 10%, 3W maximum
Display	: 4 lines of 20 characters backlit LCD
Bezel	: IP65 rated keypad
Temperature	Operating : 0° to 50° C* Storage: -25° to 80° C
Humidity	: 10% to 90% (Non condensing)
Bezel Size	: 149 H X 205 W X 50 D mm
Panel cutout	: 119 H X 152 W mm

Communication	: Using programming port of PLC
Immunity to ESD	: Level 3 as per IEC1000-4-2
Immunity to Transients	: Level 3 as per IEC1000-4-4
Immunity to Radiated RF	: Level 3 as per IEC1000-4-3
Immunity to Conducted RF	: Level 3 as per IEC1000-4-6
Emissions	: EN55011 CISPR A

* Extended temperature range available. Contact factory for details.

Protocols supported for :

- ABB AC 31 Series
- ABB AC 70 Series
- AB Micrologix
- AB SLC 500 (DF1)
- AB SLC 500 (DH485)
- Aromat FP0 Series
- Aromat FP1
- Aromat FP3
- Aromat FP Sigma
- CEGELEC ALSPA
- Crouzet Millenium
- Delta DVP Series
- FATEK PLC
- Fuji Flex
- FATEK PLC
- Fuji Flex
- GE 90-30 / Versamax (SNP)
- GE VersaMax, RJ45
- GE VersaMax, DB9
- IDEC Micro3
- IDEC MicroSmart
- Jetter nano – B
- Keyence KV Series
- Koyo DL105 / 205 / DL05
- LG-Master K Series
- LG Master K10S & 10SI PLC
- LG Master 200 S Series
- Messung XMP8 PLC Series
- Messung Nexgen 4000
- Messung Nexgen 5000
- Mitsubishi FX(8 pin con'r)
- Mitsubishi FX(25 pin con'r)
- Modbus Slave
- Modicon Quantum
- Modicon Micro
- Omron (Host Link) - 9 pin
- Omron (Host Link) - 25 pin
- Samsung SPC 10
- Samsung N70 Plus
- Siemens S7-200
- Spencer PLC
- Square D Sy/max
- Taian TP02 Series
- Telemecanique TSX-17 Series
- Telemecanique TSX-47 Series
- Telemecanique TSX-67 Series
- Toshiba - Programming Port
- Toshiba T1
- Toshiba T2
- Toshiba T Series (Link port)
- Toshiba T2 (Link port)
- Twido
- USS Protocol
- Yaskawa
- Yokogawa PLC

Note :- Refer Prizm Keypad based products family brochure for specific cable part numbers

New PLC drivers are constantly added. Please contact factory for more information.

Dimensions :

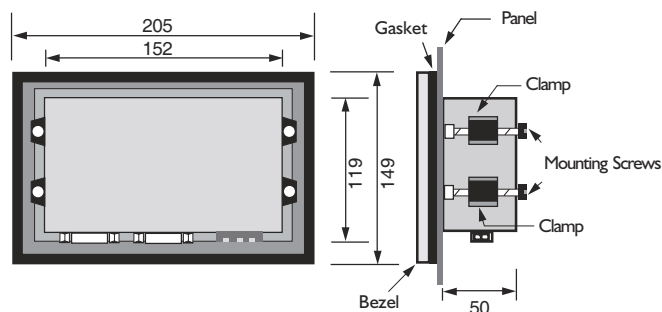

All dimensions are in mm.

Models :

Model	RTC	Power	Part Number
Prizm80-5	No	+ 5 V DC*	PZM-80-5-B
Prizm80-5	Yes	+ 5 V DC*	PZM-80-5-Y-B
Prizm80-24	No	+ 24 V DC	PZM-80-24-B
Prizm80-24	Yes	+ 24 V DC	PZM-80-24-Y-B

* PLC Powered



Renu Electronics Pvt. Ltd.

Survey No. 2/6, Baner Road, Pune - 411045, India.

Tel: +91 20 2729 2840, Fax: +91 20 2729 2839

Email: info@renuelectronics.com

Website: www.renuelectronics.com

