

ASTRA

IMO-K Series PLC Driver

www.renuelectronics.com

⌘ Tables of Contents ⌘

Preface	3
1. Introduction	3
2. Technical and Communication Details	4
3. Data Types and Addressing	6
4. Optimisations	11
5. Errors	11

⌘ Preface ⌘

This document introduces the user to the [IMO-K Series PLC driver](#) for ASTRA. This document, explains the capabilities and technical details of [IMO-K Series PLC driver](#) and how to use the driver.

⌘ Introduction ⌘

The intent of this document is to assist the users of [IMO-K Series PLC driver](#) in conjunction with the ASTRA SCADA software package. This document assumes the user to have general knowledge of [IMO-K Series PLC](#) family. The addressing scheme is similar to that of the [IMO-K Series PLC](#) programming software with some slight modifications, which are explained in subsequent chapters. The description of different data types and the addressing scheme should be understood before attempting to use the driver in ASTRA project.

The optimisation features described in this document will help to improve the performance of the system.

⌘ Technical & Communication Details ⌘

Device Make :	IMO
Device Modles :	IMOK Series PLC models K10S1, K30S, K60S (for point to point) MultiK10S1, MultiK30S, MultiK60S (for multidrop)
Device Memory :	BYTE Memory.
Communication Protocol :	IMO (Point to Point, Half Duplex). IMO (Multidrop, Half Duplex).
Communication Parameters :	
Baud Rate -	9600
Parity -	NONE
Data Bits -	8
Stop Bits -	1
Cable Connections :	Uses standard RS232C cable for point to point serial communication.
Node ID :	Node ID should be given as 1 when defining the node in ASTRA.



Technical & Communication Details



RS232 Cable Diagram for point to point:

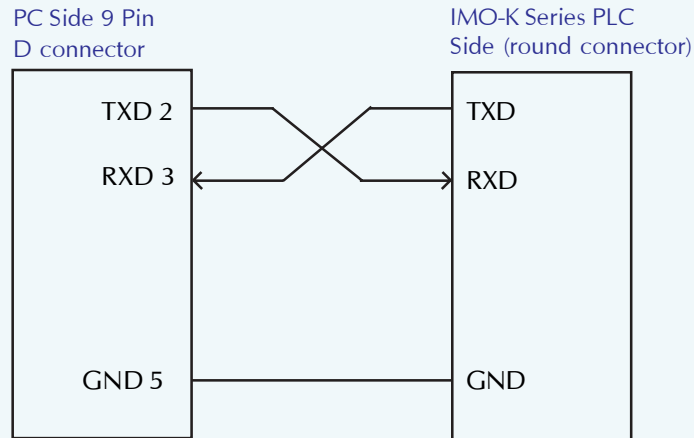

Cable Connections :

IMO-K Series PLC uses standard RS-422 connection for multidrop communication. Any standard RS485 to RS232 converter can be used. Converter used for inhouse testing was San Telequip make 2 wire converter.

Cable Diagram for multidrop:

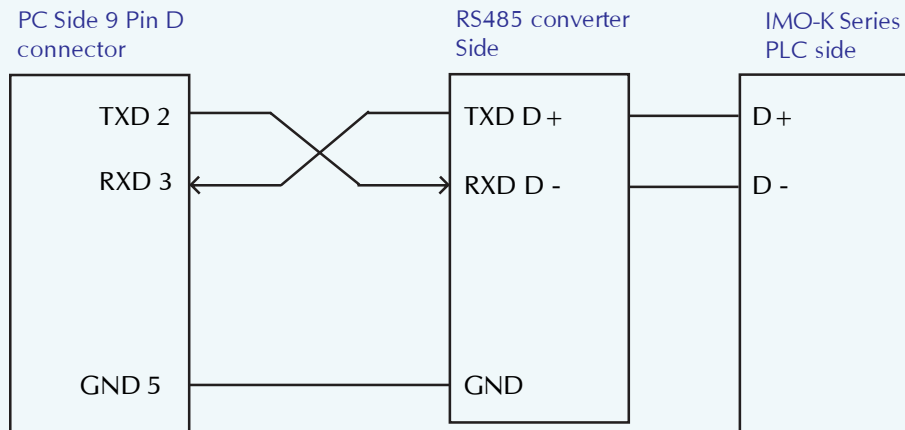

Node ID : Node ID must be given same as plc station number when defining the node in ASTRA.



Note: Selection of models MultiK10S1, MultiK30S, MultiK60S through setup nodes dialogue is required for configuring a project when the pc is connected to RS-485 terminal of the plc. If you use RS-232 terminal of plc, select models as K10S1, K30S, K60S and it will work only for point to point.

⌘ Data Types and Addressing ⌘

Data Types :

This section will describe the addressing scheme used by the IMO-K Series PLC driver for the different data types and how to enter the address in ASTRA.

I. Address Range :

Model Name : IMO-K10S1/MultiK10S1

Memory Address	Low Address	High Address	Example Addr. in ASTRA	Read / Write	Data Types
M area	0000 000 000 000	0255 031 015 014	M0000 Mb000 M000 M000	R/W R/W R/W R/W	Discrete Byte Integer, Unsigned Integer Large integer
P area	0000 000 000 000	031 003 001 000	P0031 Pb003 p000 P000	R/W R/W R/W R/W	Discrete Byte Integer, Unsigned Integer Large integer
K area	0000 000 000 000	0127 015 007 006	k0120 kb010 K005 K002	R/W R/W R/W R/W	Discrete Byte Integer, Unsigned Integer Large integer
L area	0000 000 000 000	0127 015 007 006	L0111 Lb010 l000 l002	R/W R/W R/W R/W	Discrete Byte Integer, Unsigned Integer Large integer
F area	0000 000 000 000	0255 031 015 014	f0001 fb020 F004 F002	R R R R	Discrete Byte Integer, Unsigned Integer Large integer

⌘ Data Types and Addressing ⌘

Model Name : IMO-K10S1/ MultiK10S1

Memory Address	Low Address	High Address	Example Addr. in ASTRA	Read / Write	Data Types
Timer area	0000 000 000 000	0767 095 047 046	T0000 tb000 TM000 t000	R/W R/W R/W R/W	Discrete Byte Integer, Unsigned Integer Large integer
Counter area	0000 000 000 000	255 31 15 14	C0031 Cb003 C000 c000	R/W R/W R/W R/W	Discrete Byte Integer, Unsigned Integer Large integer
Step Controller area	0000 000 000 000	0255 031 015 014	S0120 Sb010 s005 s002	R/W R/W R/W R/W	Discrete Byte Integer, Unsigned Integer Large integer
Preset Data area of Timer	0000 000 000 000	0767 095 047 046	PT0111 PTb010 PT000 pt002	R R R R	Discrete Byte Integer, Unsigned Integer Large integer
Elapsed Data area of Timer	0000 000 000 000	0767 095 047 046	ET0001 etb020 ET004 et002	R/W R/W R/W R/W	Discrete Byte Integer, Unsigned Integer Large integer
Preset Data area of Counter	0000 000 000 000	0255 031 015 014	PC0000 Pcb000 pc000 PC000	R/W R/W R/W R/W	Discrete Byte Integer, Unsigned Integer Large integer

⌘ Data Types and Addressing ⌘

Memory Address	Low Address	High Address	Example Addr. in ASTRA	Read / Write	Data Types
Elapsed Data area of Counter	0000	0255	EC0031	R	Discrete
	000	031	ECb003	R	Byte
	000	015	ec000	R	Integer, Unsigned Integer
	000	014	ec000	R	Large integer
Data Register area	0000	1023	d0120	R/W	Discrete
	000	0127	db010	R/W	Byte
	000	063	D005	R/W	Integer, Unsigned Integer
	000	062	D002	R/W	Large integer



- Note:**
- Discrete tags for step controller area is not supported.
 - Tag addresses starting with small letter use BCC check
 - Tag addresses starting with capital letter do not use BCC check .
 - All tag addresses are in decimal.

Model Name : IMO-K30S/K60S/MultiK30S/MultiK60S

Memory Address	Low Address	High Address	Example Addr. in ASTRA	Read / Write	Data Types
M area	0000	0511	M0000	R/W	Discrete
	000	063	Mb000	R/W	Byte
	000	031	M000	R/W	Integer, Unsigned Integer
	000	030	M000	R/W	Large integer
P area	0000	0095	P0031	R/W	Discrete
	000	011	Pb003	R/W	Byte
	000	005	p000	R/W	Integer, Unsigned Integer
	000	004	P000	R/W	Large integer
K area	0000	0255	k0120	R/W	Discrete
	000	031	kb010	R/W	Byte
	000	015	K005	R/W	Integer, Unsigned Integer
	000	014	K002	R/W	Large integer

⌘ Data Types and Addressing ⌘

Memory Address	Low Address	High Address	Example Addr. in ASTRA	Read / Write	Data Types
L area	0000 000 000 000	0255 031 015 014	L0111 Lb010 l000 l002	R/W R/W R/W R/W	Discrete Byte Integer, Unsigned Integer Large integer
F area	0000 000 000 000	0255 031 015 014	f0001 fb020 F004 F002	R R R R	Discrete Byte Integer, Unsigned Integer Large integer
Timer area	0000 000 000 000	2047 255 127 126	T0000 tb000 TM000 t000	R/W R/W R/W R/W	Discrete Byte Integer, Unsigned Integer Large integer
Counter area	0000 000 000 000	2047 255 127 126	C0031 Cb003 C000 c000	R/W R/W R/W R/W	Discrete Byte Integer, Unsigned Integer Large integer
Step Controller area	0000 000 000 000	0511 063 031 030	S0120 Sb010 s005 s002	R/W R/W R/W R/W	Discrete Byte Integer, Unsigned Integer Large integer
Preset Data area of Timer	0000 000 000 000	2047 255 127 126	PT0111 PTb010 PT000 pt002	R R R R	Discrete Byte Integer, Unsigned Integer Large integer

⌘ Data Types and Addressing ⌘

Model Name : IMO-K30S/K60S/MultiK30S/MultiK60S

Memory Address	Low Address	High Address	Example Addr. in ASTRA	Read / Write	Data Types
Elapsed Data area of Timer	0000	2047	ET0001	R/W	Discrete
	000	255	etb020	R/W	Byte
	000	127	ET004	R/W	Integer, Unsigned Integer
	000	126	et002	R/W	Large integer
Preset Data area of Counter	0000	2047	PC0000	R/W	Discrete
	000	255	Pcb000	R/W	Byte
	000	127	pc000	R/W	Integer, Unsigned Integer
	000	126	PC000	R/W	Large integer
Elapsed Data area of Counter	0000	2047	EC0031	R	Discrete
	000	255	ECb003	R	Byte
	000	127	ec000	R	Integer, Unsigned Integer
	000	126	ec000	R	Large integer
Data Register area	0000	4095	d0120	R/W	Discrete
	000	511	db010	R/W	Byte
	000	255	D005	R/W	Integer, Unsigned Integer
	000	254	D002	R/W	Large integer



- Note:**
- Discrete tags for step controller area is not supported.
 - Tag addresses starting with small letter use BCC check and ,
 - Tag addresses starting with capital letter do not use BCC check
 - All tag addresses are in decimal.



Optimizations



User can get an optimum performance from the driver using the following guidelines while configuring the project:

- Whenever possible, use consecutive addresses, this reduces the overhead on the communication for requested data byte, word or double word.
- When a same address is to be used for two different tags in Astra, make sure that the scan time is the same for both the tags, This ensures that the data for the address is fetched from the PLC at a time for both the tags.
- Use higher scan rates whenever possible. This ensures that the data for the critical tags with lower scan rates are fetched with minimum overhead.



Errors



While ASTRA project is running, the Event Logger displays the status of the running project and the errors, if any.

Following are the error messages which will be displayed in the event logger in case of any error condition, with their explanation (their probable cause) and the Action (most likely solution) related to this driver.

General Errors :

1. NULL Pointer for Login Data
2. NULL Pointer for Project Path
3. NULL Pointer for Tag Table
4. NULL Handle for Data Manager

Explanation : Internal Fatal Error.

Action : Contact ASTRA support.

5. Insufficient Memory for Request Manager
6. Insufficient Memory for Transaction Manager
7. Insufficient Memory for Device Manager

Explanation : Internal Fatal Error.

Action : Try making more memory available for the project by closing other running applications.



Errors



8. Cannot Pagelock Tag Table

Explanation : Internal Fatal Error.

Action : Contact ASTRA support.

9. Cannot Open File PLCTAG.DAT

Explanation : Internal Fatal Error. The input file PLCTAG.DAT does not exist or is corrupt.

Action : Open the project in the configuration mode and close it, this process recompiles the PLCTAG.DAT file.

10. Cannot Read File PLCTAG.DAT

11. Insufficient Memory for Tag

12. Insufficient Memory for Tag2

13. Insufficient Memory for Tag Container

14. Insufficient Memory for Node

15. Insufficient Memory for Node Container

Explanation : Internal Fatal Error.

Action : Try making more memory available for the project by closing other running applications.

16. No Tags in the Project

Explanation : Internal Fatal Error. The driver detected no valid tags in the project.

Action : Recheck the project in the configuration mode. See if any tags are assigned to this particular device. See if the Node details are correct.

17. No Valid Nodes in the Project.

Explanation : Internal Fatal Error. The driver detected no valid nodes in the project.

Action : Recheck the project in the configuration mode. See if the Node details are correct.

18. Multidrop not Supported

Explanation : Internal Fatal Error. An attempt was made to attach two nodes on the same driver when Multidrop is not supported.

Action : Recheck the project in the configuration mode. See if the Node details are correct.

19. Multiple nodes with same ID

Explanation : Internal Fatal Error. An attempt was made to attach two nodes on the same driver with same Node IDs.

Action : Recheck the project in the configuration mode. See if the Node details are correct.



Errors



20. Insufficient Memory for Request

22. Insufficient Memory for Request Container

24. Insufficient Memory for Action

26. Cannot Create Communication Window

Explanation : Internal Fatal Error.

Action : Try making more memory available for the project.

21. Insufficient Memory for Request2

23. Insufficient Memory for Dummy Request

25. Insufficient Memory for Action Container

27. Cannot Open Communication Port

Explanation : Internal Fatal Error. Could not initialize the Communication port for the given settings.

Action : For the selected Communication port, check for -

- ⊙ If the port physically exists.
- ⊙ If the Communication hardware uses standard base addresses. COM1 uses hex 3F8 and COM2 uses hex 2F8.
- ⊙ If there is any IRQ contention at the hardware level. COM1 uses IRQ4 and COM2 uses IRQ3.
- ⊙ If any other program is already using the Communication port you have requested for.
- ⊙ If any DOS level TSRs are running which are using the Communication port you have requested for.
- ⊙ If a mouse driver is installed on the same Communication port you have requested for in Windows environment.
- ⊙ If a mouse driver is installed on the same Communication port you have requested for on DOS environment.
- ⊙ If you have directly manipulated the PROJECT.INI file section [COM1] or [COM2], check if the settings for Baud Rate, Data Bits, Stop Bits and the Parity are standard. Try using the Communication port setting utility provided with Astra in case you are in doubts about the standard settings.

28. Cannot Build Communication DCB

Explanation : Internal Fatal Error. Could not initialize the Communication port for the given settings.

Action : If you have directly manipulated the PROJECT.INI file section [COM1] or [COM2], check if the settings for Baud Rate, Data Bits, Stop Bits and the Parity



Errors



are standard. Try using the Communication port setting utility provided with Astra in case you are in doubts about the standard settings.

29. Cannot Set Communication State

Explanation : Internal Fatal Error. Could not initialize the Communication port for the given settings.

Action : If you have directly manipulated the PROJECT.INI file section [COM1] or [COM2], check if the settings for Baud Rate, Data Bits, Stop Bits and the Parity are standard. Try using the Communication port setting utility provided with Astra in case you are in doubts about the standard settings.

30.NULL Pointer for Model Names

31.Read Queue Full

Explanation : Internal Fatal Error.

Action : Contact Astra support.

32. Device Time Out

Explanation : The Device did not respond and the Device driver timed out. The Driver will retry the request to Device for a specified number of times and if the Device still does not respond the driver will HALT its transactions with the Device.

Action : If this happens during **initialization**, check –

- ⊙ Whether the Device power is on.
- ⊙ Whether the cable connections to the device are proper.
- ⊙ Whether the Node ID settings are proper in case the Device supports it.
- ⊙ Whether the Device model is the same as configured in the Node Configuration.
- ⊙ Whether the Communication hardware is proper and works.
- ⊙ Whether strong EMI or RFI fields are existent which cause noise on the Communication line.
- ⊙ Whether some turnaround delay is required, try changing the entries in the DRIVERS.INI file. This may be typically required for faster PCs on which Astra runs.

If this happens during the **Run**, check –

- ⊙ Whether other applications block the Windows, in such a case the retry mechanism will normally re-establish the Communication.
- ⊙ Whether the cable connections have been disturbed.



Errors



⊙ Whether the Device has malfunctioned.

⊙ Whether the Communication hardware is proper and works.

33. Invalid IEEE Format

Explanation : The 32 bits read from the Device contained bit values such that it could not be interpreted as a valid IEEE format.

Action : Use OEM software and initialize floating type tags in the plc.

34. Write Queue Full

Explanation : The write request sent by the Astra is queued for faster execution, the current limit for the queue size is 300. If the queue is full this message will be prompted and the latest request will be ignored.

Action : Go to the project configuration file and put an entry with section name "QueueSize". Under this section name, put a key name "WriteQueue", so that it looks like: [QueueSize]

WriteQueue = WXY

Where,

WXY can be upto 5000.

35. No Valid Tags in the Project

Explanation : Internal Fatal Error. The driver detected no valid tags in the project.

Action : Recheck the project in the configuration mode. See if any tags are assigned to this particular device. See if the Node details are correct.

36. Insufficient Memory for Register

37. Insufficient Memory for Tag Container2

38. Insufficient Memory for Register Container

Explanation : Internal Fatal Error.

Action : Try making more memory available for the project.

39. Tag Address Invalid

40. Tag Address Invalid2.

Explanation : The address entered for a Tag is invalid.

Action : Reconfigure the project and check.

41. Driver Scan Halted

42. Driver Scan Halted2

Explanation : The driver has stopped communicating with the device. This may happen in two situations –



Errors



- ⊙ When the initial scan is complete - in this case this is just a status information.
 - ⊙ When time-out has occurred and retry for establishing communication has failed.
- Action** : In the second case check –
- ⊙ If the cable connections have been disturbed.
 - ⊙ If the Device has malfunctioned.
 - ⊙ If the Communication hardware is proper and works.
43. Cannot Find INI File Entry, Setting Default Port
- Explanation** : The [PROTOCOL] section in PROJECT.INI does not have the driver name against the COM1 or the COM2 entry. In such a case default COM1 is selected as the Communication port.
- Action** : Run the Communication port setting utility provided with Astra and set all the parameters properly.
44. Cannot Initialise Driver Twice
- Explanation** : Due to some abnormal termination in a previous run the Device Driver has not unloaded itself and hence could not reinitialise itself.
- Action** : Restart the project.
45. Cannot Run Without Initialisation 46. Cannot Run Without Initialization2
47. Cannot Write Without Initialisation 48. Cannot Build Frames Without Initialisation
- Explanation** : Due to some abnormal termination in a previous run, the Device Driver has not unloaded itself and hence could not reinitialise itself.
- Action** : Restart the project.
49. NULL Pointer for Queue
- Explanation** : Internal Fatal Error.
- Action** : Contact ASTRA support.
50. Invalid IEEE Format2
- Explanation** : The 32 bits read from the Device contained bit values such that it could not be interpreted as a valid IEEE format.
- Action** : Use OEM software and initialise floating type tags in the device.
51. Cannot Pagelock Buffer
- Explanation** : Internal Fatal Error.



Errors



Action : Contact ASTRA support.

52. Device Response Delay

Explanation : The Device did not respond and the Device driver timed out. The Driver will retry the request to Device for a specified number of times and if the Device still does not respond the driver will HALT its transactions with the Device.

Action : If this happens during **Initialisation** check –

- ⊙ If the Device is powered on.
- ⊙ If the cable connections to the device are proper.
- ⊙ If the Device model is the same as configured in the Node Configuration.
- ⊙ If the Communication hardware is proper and working.
- ⊙ If strong EMI or RFI fields are existent which cause noise on the Communication line.

If this happens during the **Run** check –

- ⊙ If in case other applications block the Windows, in such a case the retry mechanism will normally re-establish the Communication.
- ⊙ If the cable connections have been disturbed.
- ⊙ If the Device has malfunctioned.
- ⊙ If the Communication hardware is proper and working.

53. Response Check Sum Error

Explanation : The Device did respond but the bytes received were corrupt. The Driver will retry the request to Device.

Action : If this happens during **Initialisation** check –

- ⊙ If the Communication hardware is proper and working.
- ⊙ If strong EMI or RFI fields are existent which cause noise on the Communication line.
- ⊙ If the Communication port settings are proper.

If this happens during the **Run** check –

- ⊙ If the cable connections have been disturbed.



Errors



- ⊙ If the Device has malfunctioned.
- ⊙ If the Communication hardware is proper and working.

54. Data Over Flow

Explanation : Unexpected data in large volume was received on the Communication port.

Action : Check –

- ⊙ If the cable connections have been disturbed.
- ⊙ If the Device has malfunctioned.
- ⊙ If the Communication hardware is proper and working.

55. Model Name Invalid

Explanation : Internal Fatal Error. The model name associated with a particular Node was invalid.

Action : Open the project in the configuration mode. Check the model in the Node Configuration and close it.

56. Cannot Open File PLCTAG.DAT 2

57. Cannot Read File PLCTAG.DAT 2

58. Cannot Read File PLCTAG.DAT 3

Explanation : Internal Fatal Error. The input file PLCTAG.DAT does not exist or is corrupt.

Action : Open the project in the configuration mode and close it, this process recompiles the PLCTAG.DAT file.

59. Invalid BCD Format for a WORD

Explanation : The 16 bits read from the Device contained bit values such that it could not be interpreted as a valid BCD format.

Action : Use OEM software and initialise respective tags in the device.

60. Invalid BCD Format for a DWORD

Explanation : The 32 bits read from the Device contained bit values such that it could not be interpreted as a valid BCD format.

Action : Use OEM software and initialise respective tags in the device.

61. Invalid number for conversion to BCD for WORD

Explanation : The 16 bits given for write from ASTRA to the Device contained bit values such that it could not be interpreted as a valid BCD format. Write will not be done in these cases.

Action : Avoid such values.



Errors



62. Invalid number for conversion to BCD for DWORD

Explanation : The 32 bits given for write from ASTRA to the Device contained bit values such that it could not be interpreted as a valid BCD format. Write will not be done in these cases.

Action : Avoid such values.

63. Error Composing Write Request

Explanation : Write request could not be composed. This may happen in two cases –

⊙ Invalid number for write.

⊙ Write Queue full.

Action : Avoid non interpretable values, Avoid writing too fast. Increase WriteQueueSize in project.ini file section [QueueSize]. Lower limit for WriteQueueSize is 300 and the upper limit is 5000.

64. Error Composing Read Request After Write

Explanation : A read request immediately following a write request could not be composed.

This may happen in two cases –

⊙ Invalid number for write.

⊙ Write Queue full.

Action : Avoid non interpretable values, Avoid writing too fast. Increase WriteQueueSize in project.ini file section [QueueSize]. Lower limit for WriteQueueSize is 300 and the upper limit is 5000.

65. Node Failed.

Explanation : Internal Fatal Error. The Node was not able to communicate. In case of Multidrop DEVICE system the node id given to the nodes may be same or cable from PC to DEVICE may be faulty.

Action : Open the project in the configuration mode check the Node Configuration and close it. For Multidrop communication check the node ID. Check the cable.

66. Cannot Open File NODES.DAT

67. Cannot Read File NODES.DAT 2

Explanation : Internal Fatal Error. The input file NODES.DAT does not exist or is corrupt.

Action : Open the project in the configuration mode and close it, this process recompiles the NODES.DAT file.



Errors



68. Node set on by user.

Explanation : Not an error . It indicates that node is selected by the user. For ASTRA generated default tags for a DEVICE, in that if command tag is 0 then this message is displayed.

Action : None , as it indicates that node is selected by the user.

69. Node set off by user.

Explanation : Not an error . It indicates that node is unselected by the user. For ASTRA generated default tags for a DEVICE in that if command tag is 1 then this message is displayed.

Action : None, as it indicates that node is unselected by the user.

73. Node manager proc address not defined.

Explanation: Internal Fatal Error.

Action: Contact Astra support.



Errors



Errors specific to IMOKS:

74. NAK received while reading tag 't' of node 'n'

Explanation : When this message is displayed in the event logger, it indicates that plc has sent NAK message while reading tag 't' of plc with station number 'n'. This may happen when command sent by the PC is not recognised by the PLC. Or, if communication parameters in project.ini file are not set correctly, plc will send NAK (0x15) character.

Action : Use OEM to verify the particular tag is causing the error.
Check the communication parameter settings in project.ini file.

75. NAK received while writing tag 't' of node 'n'

Explanation : When this message is displayed in the event logger, it indicates that plc has sent NAK message while writing tag 't' of plc with station number 'n'. This may happen when command sent by the PC is not recognised by the PLC. Or, if communication parameters in project.ini file are not set correctly, plc will send NAK (0x15) character.

Action : Use OEM to verify the particular tag is causing the error.
Check the communication parameter settings in project.ini file.



Renu Electronics Pvt Ltd.

S.No. 2/6, Baner Road,

Pune 411045, India.

Tel: + 91 20 2729 2840,

Fax: + 91 20 2729 2839

Email: info@renuelectronics.com

Website: www.renuelectronics.com

