



Field Analog Input Outputs.

FIOA-0402-U

Universal Analog I/O Modules :

- Low cost compact Analog I/O modules with DIN rail mounting
- Programmable inputs allow same modules to accept RTD, Thermocouple, mA, mV and Volts
- 12 bit resolution
- 4 universal analog inputs and 2 analog outputs
- High Speed Modbus RTU (Slave) communication
- User definable Address, Baud rate and Parity through Software Configuration
- 2 wire RS485 port provided on pluggable terminal block
- Can be multi dropped as Modbus Slave on RS485 Network
- Indication for Diagnostics, Power and Communication
- Programming through standard Prizm softwareFREE!!
- CE marked with optional UL / CSA certification

Possible Applications :

FIOA can be used for various applications in industries. Typical configuration includes the following :

1. Add analog I/O to your Controller.



2. Multiple FIOA units (Modbus Slaves) connected to Modbus Master

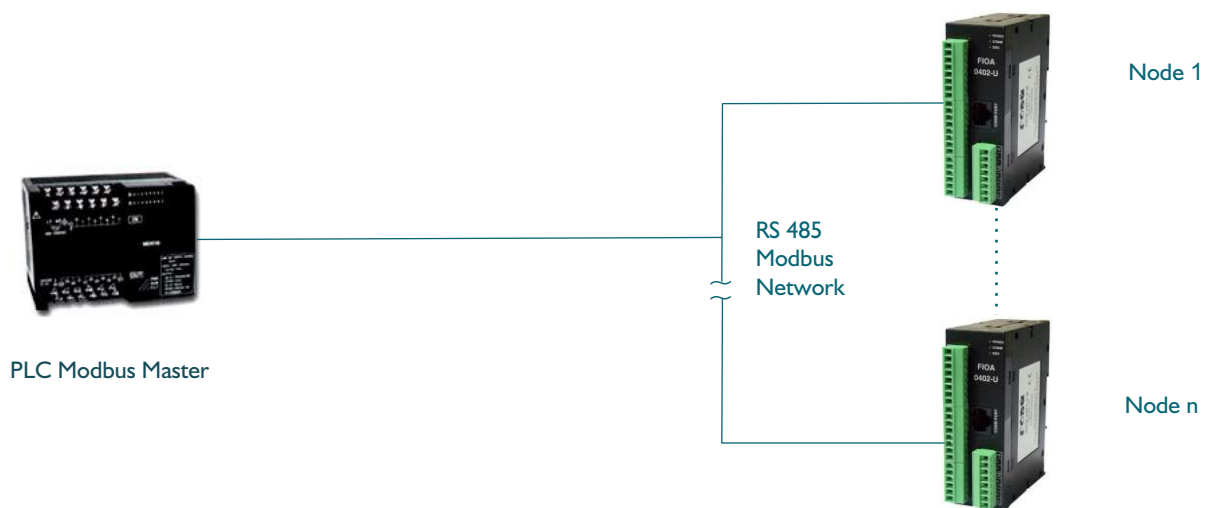

3. Data Acquisition Application (SCADA Connectivity)

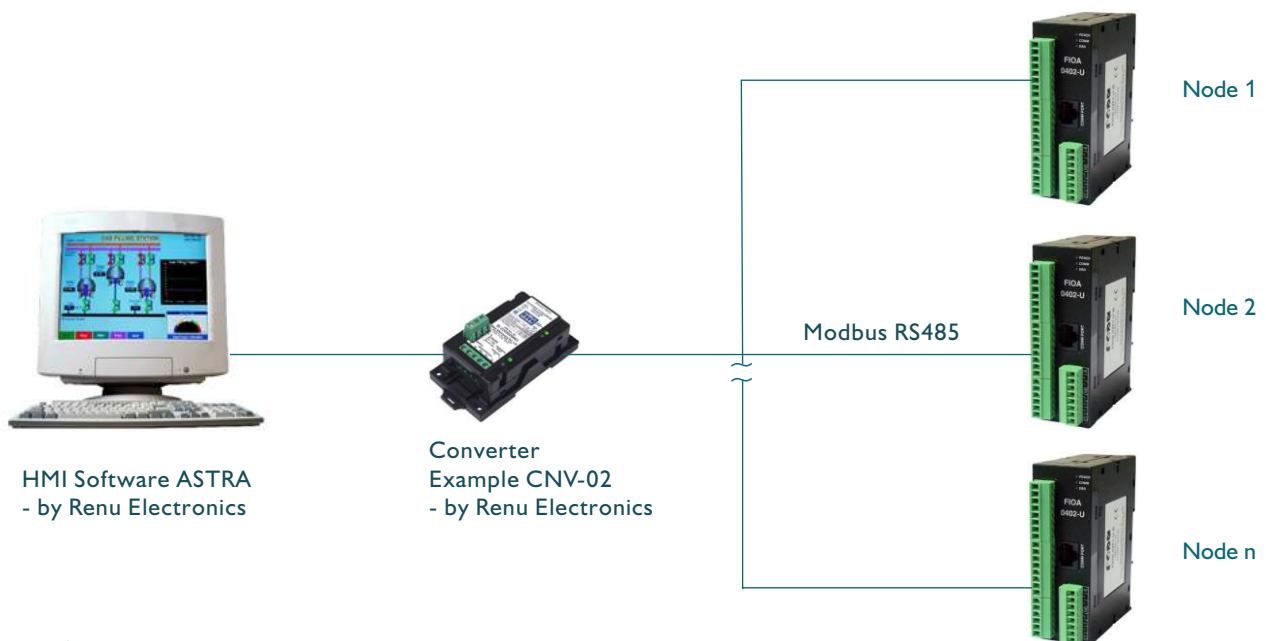

Typical Wiring Diagrams :

Analog Inputs

1. Current Input Connections:

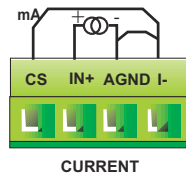

2. Voltage Input Connections:

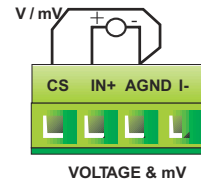

3. RTD Input Connections:

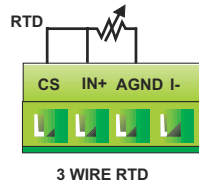

4. Thermocouple Input Connections:

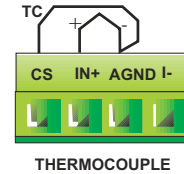

Analog Outputs

1. Current Output Connections:

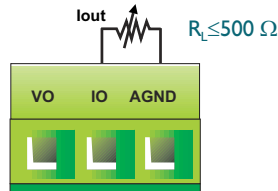

2. Voltage Output Connections:

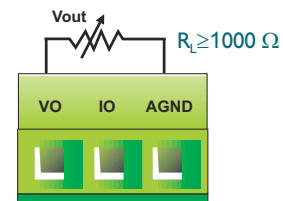

Specifications :

For mVolt inputs :

Uses 0-100 mV input range resolved in 12 bits.
Total error : $\pm 0.2\%$ of scale ± 1 bit.

For Current inputs :

Uses 0-20mA input range with 4.7 Ω precision shunt resolved in 12 bits.
Total error : $\pm 0.2\%$ of scale ± 1 bit.

For Volt inputs :

Uses 0-10V input range resolved in 12 bits.
Total error : $\pm 0.2\%$ of scale ± 1 bit.

For RTD input :

Uses 3 wire compensation technique. Excitation Current is 0.5mA.
Power dissipated in RTD is 0.025mW @ 100 Ω .
Range supported : -200 to 850 $^{\circ}$ C.

For Thermocouple Input :

Uses 0-100mV input range resolved into 12 bits.
Cold junction error is 1 $^{\circ}$ maximum and 0.5 $^{\circ}$ typical.
Total error : 0.5% of scale ± 1 bit + CJC error
Response Time : Worst case 25mSec approx.
Temperature Drift (for Digital Count) : 60 PPM
Normalization Factor : 0-99 (Software configurable)

Input Type	Temperature Range	1 Bit Corresponds to
J	-50 to 1200 $^{\circ}$ C	0.43 $^{\circ}$ C
K	-50 to 1373 $^{\circ}$ C	0.61 $^{\circ}$ C
E	-50 to 1000 $^{\circ}$ C	0.32 $^{\circ}$ C
R	-50 to 1769 $^{\circ}$ C	2.04 $^{\circ}$ C
S	-50 to 1769 $^{\circ}$ C	2.31 $^{\circ}$ C
B	0 to 1820 $^{\circ}$ C	3.21 $^{\circ}$ C
N	-50 to 1300 $^{\circ}$ C	0.7 $^{\circ}$ C
T	-50 to 400 $^{\circ}$ C	0.47 $^{\circ}$ C

Analog Outputs

Resolution	12 Bit
Load: 4-20 mA 0-10 V DC	Less than 500 Ω Minimum 1k Ω

General Specifications :

Power	: 24V DC $\pm 10\%$, 4W maximum	Communication Port	: 2 wire RS485, RS232, CMOS logic Signals are available on RJ45 comm port. Same two wire RS485 signals are provided on terminal block
Operating Temperature	: 0 $^{\circ}$ to 50 $^{\circ}$ C	Driver	: Modbus RTU Slave
Storage Temperature	: -20 $^{\circ}$ to 80 $^{\circ}$ C	Baud rate	: 9600, 19.2k, 57.6k or 115.2k (software configurable)
Humidity	: 10% to 90% (Non condensing)	Parity	: Odd, Even or None (software configurable)
Mounting	: DIN rail mounting	Device ID	: 1-255 (Software configurable)
Size	: 100 W x 70 H x 35 D		
Immunity to ESD	: as per IEC61000-4-2		
Immunity to Fast Transients	: as per IEC61000-4-4		
Immunity to Radiated electromagnetic field	: as per IEC61000-4-3		
Immunity to Conducted disturbances	: as per IEC61000-4-6		
Surge	: as per IEC61000-4-5		
Radiated emission	: as per EN61000-6-4		

Basic Operations :

FIOA 0402 U is Analog Input Output Model having 4 Universal Analog inputs and 2 Analog outputs. The Analog inputs can be Voltage (0-10V), Current (0–20 mA, 4–20 mA), mV (0–100 mV, 0–50 mV), RTD (PT 100 Alpha I and Alpha2 constant), Thermocouple (B,R,S,E,J,K,N,T).

Each input channel can be configured independently to work as any of the above type as per configuration made in the PRIZM software. The Analog outputs can be Voltage (0–10 V) or Current (4–20 mA). Output channels also are software configurable to current or voltage. Unit supports standard Modbus RTU (slave) protocol for communicating with master device.

Analog inputs and outputs are isolated from the communication port. Power supply is isolated from all internal circuitry.

Input and Output channels of the FIOA are user configurable and any combination of input types is possible. Prizm Setup Software helps the user to configure the FIOA units and use them as per his requirements.

System requirements for Prizm Setup Software are:

Device	Minimum
IBM compatible PC with Pentium processor	266 MHz Pentium® II or higher Pentium compatible CPU
Operating System	Windows® 2000 and above (except Windows® Vista)
System RAM	At least 64 megabytes (MB) of RAM
Hard disk	150 MB free memory space
VGA Monitor Color settings Resolution	800x600 with 24 bit true color
Mouse	Microsoft® mouse or compatible pointing device

Other Items required for FIOA configuration:

1. FIOA unit
2. +24VDC regulated power supply
3. Prizm Setup Software
4. FIOA to Device cable
5. Configuration download cable (IBM-005-H-00)

Dimensions :

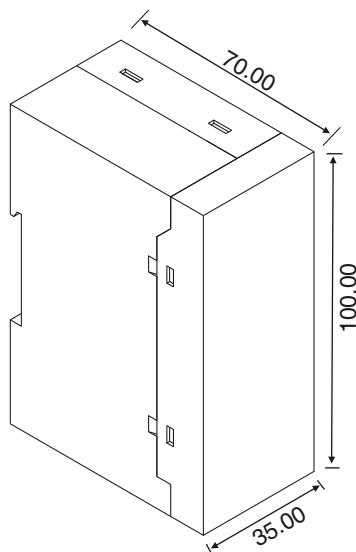

All dimensions are in mm.

Pinout of COMM Port :

Pinouts of RJ connector is as shown below:

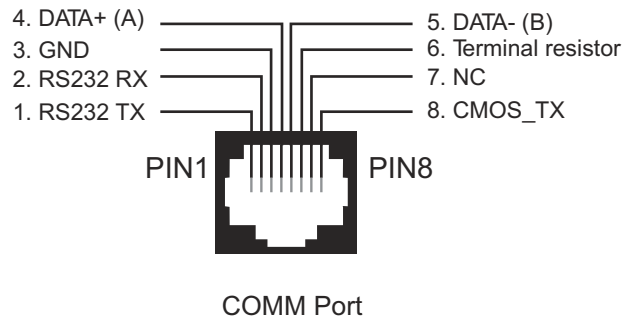

Renu Electronics Pvt. Ltd.

Survey No. 2/6, Baner Road, Pune - 411045, India.

Tel: +91 20 2729 2840, Fax: +91 20 2729 2839

Email: info@renuelectronics.com

Website: www.renuelectronics.com

