

◆ **Technical Support**

For Technical support please contact factory along with the unit serial number displayed on the unit. Also provide information of the PLC being used. Usually, including your application also provides a lot of help. If possible e-mail the application to us.

Renu Electronics Pvt. Ltd.
 Survey No. 2/6, Baner Road, Pune – 411 045.
 Maharashtra, INDIA
 Tel: +91 20 27292840
 Fax: +91 20 27292839
 E-mail: support@renuelectronics.com
 Website: www.renuelectronics.com



**QUICK START
 MANUAL FOR
 CNV-03-B**



Doc. No.: QM/CNV-03-B
 REV No.: 2

Follow the wiring diagram in Figure 2 to connect the repeater to 2-wire half-duplex network. For 2 wire communication, consider TX+ as (A) & connect it to network's (A), similarly consider TX- as (B) & connect it to network's (B).

For 2 wire with termination, user have to connect 180E resistor externally between TX+ & TX-.
 For 4 wire termination will be selected using switch "4" on the unit.

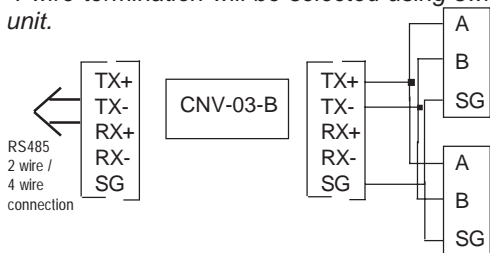

◆ **4 Wire RS485 Full Duplex**

This communication mode is used to connect several RS485 devices in master/slave fashion, where only one unit (slave) talks at a time. During the marking or idle state RS485 driver is disabled and the data lines are held in the marking state by the 1K Ohm pull up and pull down resistors.

To set the repeater to 4-wire RS485 full duplex, set switch 1 in OFF position. Set switch 2 in ON. Set switch 3 in ON position if 180E termination is used else set it to OFF. If termination value is other than 180E then connect it between RX+ & RX- & set switch 3 in OFF position

Thank you for purchasing our Gateway series product - CNV-03-B (RS485 Repeater). **Read this manual thoroughly before installing and operating the unit.**

This is only a Quick Start Manual. For detailed information on this product download the user manual free from the download section of our website. For a printed copy of this manual contact our nearest sales office.

This document is based on information available at the time of its publication and may not cover all the details or variations in hardware or software. Renu Electronics reserves the right to update information in this publication without prior notice.

Note:

Any mechanical or electrical modification to this unit will void all warranties.

No Termination S/W	Position	With Termination S/W	Position
1	OFF	1	OFF
2	ON	2	ON
3	OFF	3	ON

Follow the wiring diagram in Figure 3 to connect the repeater to 4-wire full-duplex network. Connect TX +(TXA) to RX+ (RXA), TX- (TXB) to RX- (RXB) at both the ends and a ground wire must be connected between all the units. When multiple slaves are on the same network, the connection between the master and each slave must be same as shown in Figure3. This will cause all the slaves to have their transmitters and receivers connected & not allow communication between the slaves themselves.

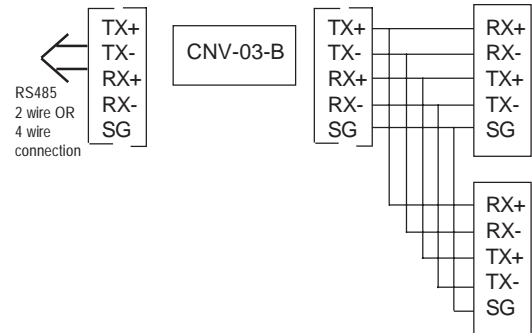

◆ Installation and Operating Instructions

Power, input and output (I/O) wiring must be in accordance with Class I, Division 2 wiring methods (Article 501-4 (b) of the National Electrical Code, NEPA 70) and in accordance with the authority having jurisdiction.



A. **"THIS EQUIPMENT IS SUITABLE FOR USE IN CLASS I, DIVISION 2, GROUPS A, B, C AND D OR NON-HAZARDOUS LOCATIONS ONLY."**



B. **"WARNING - EXPLOSION HAZARD - SUBSTITUTION OF COMPONENTS MAY IMPAIR SUITABILITY FOR CLASS I, DIVISION 2."**



C. **"WARNING - EXPLOSION HAZARD - DO NOT DISCONNECT EQUIPMENT UNLESS POWER HAS BEEN SWITCHED OFF OR AREA IS KNOWN TO BE NON-HAZARDOUS."**

Connect RX+ to TX+ and RX- to TX-, at both the ends and signal ground to signal ground.

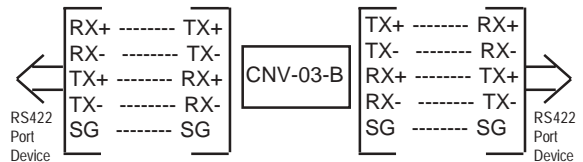

◆ 2 Wire RS485 Half Duplex

This communication mode is used to connect several RS485 devices to the same network with minimum number of wires when only one unit talks at a time. During the marking or idle state RS485 driver is disabled and the data lines are held in the marking state by the 1K-Ohm pull up and pull down resistors. To set the repeater for 2-wire RS485 half duplex, set switch 1 and switch 2 in ON position. Set switch 3(Termination) in ON position if 180E termination is used else set it to OFF. If termination value is other than 180E then connect it between RX+ & RX- & switch 3 in OFF position.

No Termination S/W	Position	With Termination S/W	Position
1	ON	1	ON
2	ON	2	ON
3	OFF	3	ON

◆ 4 Wire RS422 Full Duplex

This communication mode is generally used for point-to-point communication over long distances with better noise immunity than RS232/CMOS. The RS422 driver and receiver are always enabled to allow full duplex communications. To achieve proper operations there must be a pair of wires dedicated to the driver, a pair dedicated to the receiver and a ground reference wire for a total of 5 lines. To set the repeater for 4-wire RS422, Set switch 1 and switch 2 in OFF position. Set switch 3 (Termination) in ON position if 180E termination is used else set it to OFF. If termination value is other than 180E then connect it between RX+ & RX- & set switch 3 (Termination) in OFF position.

No Termination S/W	Position	With Termination S/W	Position
1	OFF	1	OFF
2	OFF	2	OFF
3	OFF	3	ON

◆ Panel Mounting

The Universal RS485 repeater may be installed by either securing directly to the mounting surface using a mounting plate or by mounting to a DIN rail.

While installation; tighten the mounting screws evenly to a torque between 0.6 and 0.7 Nm to maintain water and dust resistance.

To install: 1. Determine your spacing requirements.

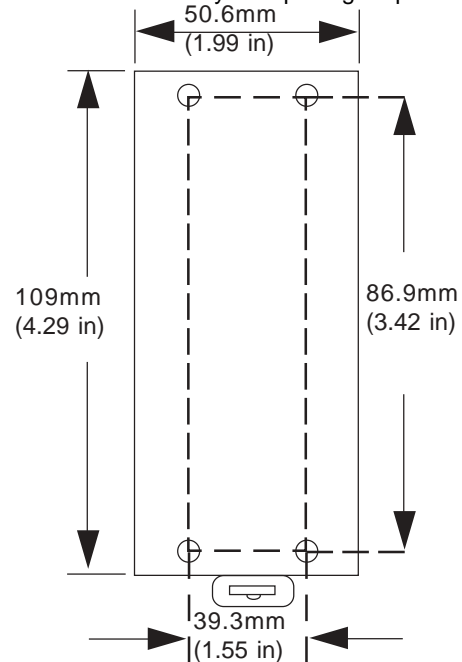

◆ Introduction

RS485 communication levels can physically support 32 nodes up-to a maximum distance of 1200 mtrs. CNV-03-B is a RS422/RS485 repeater. CNV-03-B unit is used where more than 32 nodes are to be connected in the RS485 network or the distance between two nodes is more than 1200 mtrs. It increases number of nodes connected in RS485 network. One CNV-03-B can increase maximum 32 nodes in the network. Multiple CNV-03-B units can be used to support maximum 255 nodes in one network. CNV-03-B has 2 communication ports. Both the communication ports are screw type easy to use connectors. Communication ports as well as power port are isolated. CNV-03-B supports both 2 wire/4 wire RS485 and RS422 configuration. It has switch settings to select 2 wire / 4 wire communication on each COM port. CNV-03-B operates on 24 VDC external supply.

Specifications:

Power Supply : 24 VDC +/- 10 %, 2Watt max
 Communication : Two ports as follows:
 COM1 : RS422 / RS485
 COM2 : RS422 / RS485

Data Rates : Up to 115.2 kbps.
 Distance : Units transmit up to 4000ft (1200m).
 Temperature : Operating: 0 to 60 °C
 Storage : - 40 to 90 °C

Power port Isolation :1Kv Isolation between communication ports and power supply.
 Com Port Isolation :1Kv Isolation between COM1 and COM2 through optoisolation.
 Humidity :10% to 90% (Non condensing)
 Immunity to ESD :Level 3 as per IEC1000-4-2
 Immunity to Transients :Level 3 as per IEC1000-4-4
 Radiated Susceptibility :Level 3 as per IEC1000-4-3
 Emissions :EN55011 CISPR A
 Certifications :CE , CSA and UL
 Dimensions :101mm(L)X40mm(D)X51mm(W)
 Weight :125 g approximately

2. For mounting plate installation:
 - a. Drill holes into your mounting surface (#36 drill recommended).
 - b. Align the repeater to the mounting plate and snap the unit into place.
 - c. Fasten the mounting plate to your surface with four screws (6-32 recommended).

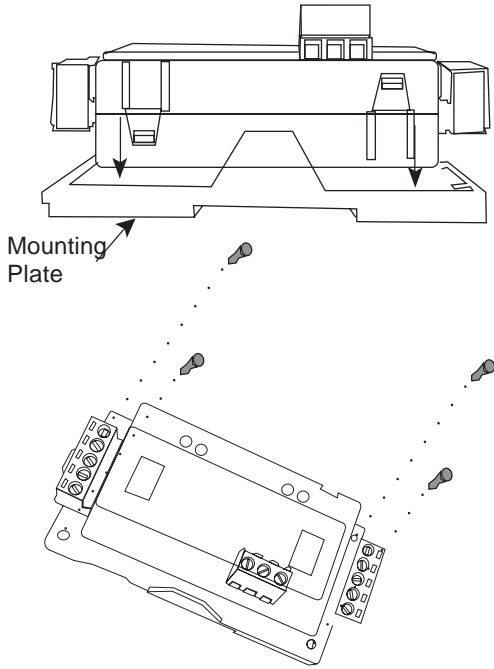

◆ **Switch Settings**

There are 4 switches for setting:

1. 4-wire/2-wire configurations
2. RS422/RS485 selection
3. With/Without Termination

Following table shows switch positions for selection of the above parameters

Switch	ON	OFF
1	2 Wire	4 Wire
2	RS485 selection	RS422 selection
3	Termination	No Termination
4	Not used	Not used

◆ **Port Details**

The unit has

- a) Weid Muller connector (2 nos.)
- b) Terminal blocks (1 no.)
- c) Switches for different settings (8 nos.)

RS422/RS485 Ports:

Connector : Weid Muller

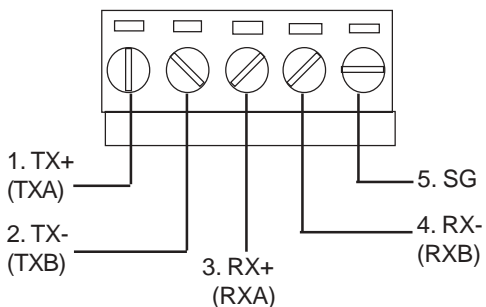

3. For DIN rail installation:

- a. Mount the DIN rail to your mounting surface.
- b. Align the repeater to the mounting plate and snap the unit into place.
- c. Hook the top slot of the mounting plate over the DIN rail.
- d. While pressing the unit against the rail, snap the repeater into place.

